

RDP60 Paver

Specification Sheet



Ordering Information						
Model	Installation	Power	Color Temp.	Optics	Voltage	Options
RDP60	TM TS	L	27	LL	24	C*
			30			C3
		H	40			C6 C9



Application

- Marker light
- Architectural and landscape lighting
- Recessed floor installation
- Gravel, soil or concrete
- UL STD 1598, IP67, Wet location, drive over rated 1500 kg (3300 lb)

Luminaire

- Sustainable design, replaceable LED module
- Remote power supply
- Sandblasted tempered glass 10mm (3/8") thick, with inner opal film to create marker light
- Aluminium construction fixture body
- Stainless steel type 304 flange
- Snap in installation with no exposed hardware
- Supplied with oil and water resistant 0,3m (1') feed cable as standard
- IK10

Color Temperature

- 27 - 2700K
- 30 - 3000K
- 40 - 4000K
- 2 Step MacAdam
- CRI: > 85

Optics

- LL - 120° even illumination

Voltage

- 24 - 24VDC fixture voltage

Options

- C* - standard feed cable 0,3m (1')
- C3 - luminaire supplied with 3m (10') feed cable
- C6 - luminaire supplied with 6m (20') feed cable
- C9 - luminaire supplied with 9m (30') feed cable

Installation

- Trim (TM)
- Trimless (TS)

Power - Delivered lumens

- L - 2,9W, 2700K - 4000K, 52 lm
- H - 4W, 2700K - 4000K, 136 lm

Installation housing

- RD60C - Concrete
- RD60T - Tiles

POWER SUPPLIES

List of proposed power supplies that are to be ordered separately. Please click [link](#) for list of available drivers.

Click [here](#) for voltage drop and distances.

Trim (TM)

Ø75mm
(Ø2.9")

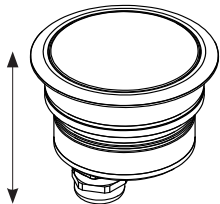

H-68mm
(2.7")



Trimless (TS)

Ø64mm
(Ø2.5")

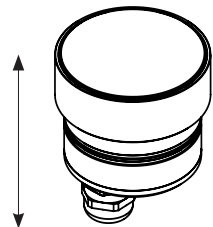

H-68mm
(2.7")



International: +385 52 255 324 filixlighting.com

info@filixlighting.com

Europe/GmbH: info@filixlighting.com

Europe MENA: info@filixlighting.com

North America: filixlighting-usa.com info@filixlighting.com

Filix reserves the right to make technical changes without notice.

RDP60 Paver

Dimensions



Note:
For details on specific depths, tiling thickness and other please refer to both Installation instructions for fixture and housing.

Installation housing - RD60C - Concrete installation

Installation details

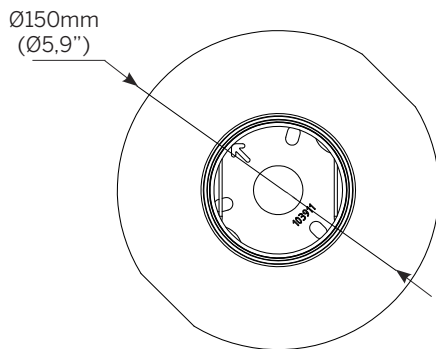
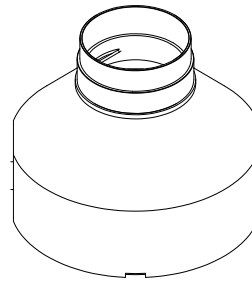
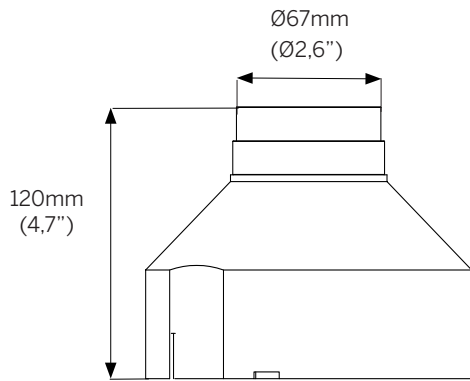

Installation housing - RD60T - Tiles installation

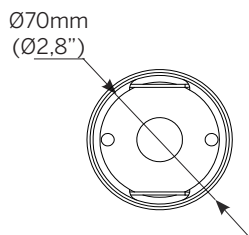
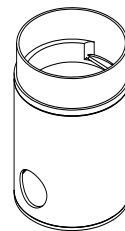
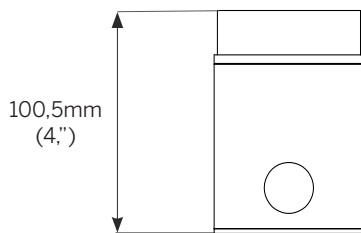

International: +385 52 255 324 filixlighting.com
info@filixlighting.com
Europe/GmbH: info@filixlighting.com
Europe MENA: info@filixlighting.com
North America: filixlighting-usa.com info@filixlighting.com

Filix reserves the right to make technical changes without notice.